

# BEEF CATTLE MANAGEMENT PRACTICES



Generally success or failure in the cattle business depends to a large extent upon doing the right things at the right time. Whether this is the result of good training and knowledge, good judgment or intuition, the diligence with which some producers carry out certain management practices skillfully makes them more successful than others. This is often referred to as the MAN in MANagement.

## Management of Breeding Animals

### Calving Season

For efficient beef production, every cow should produce a calf each year. It is best if all calves are born within a 60- to 90-day period. A controlled, seasonal calving program is necessary to carry out good management practices.

- It facilitates the keeping of good production records, thus making comparisons between cows and calves more meaningful for culling and selection purposes.
- Better care can be provided to cows during calving. It is very difficult to properly check cows that are calving year-round.
- Seasonal calving helps manage a good herd health program. If cattle producers perform such practices as identification, castration, dehorning, vaccination, worming and weaning within a short time span or all at one working, the labor requirement will be greatly reduced.
- Pregnancy testing can be done more conveniently on a seasonal calving program.
- The nutritional requirements vary greatly between animals at the various stages of reproduction and production. When all cows are in a similar stage of production, brood cow nutrition can be properly managed.
- Finally, seasonal calving improves the opportunity for successful marketing.

Some producers may prefer a split calving season. For example, the cattle may be divided into two herds with one calving in October, November and December and the other in February, March and April. A split calving season enables each bull to breed more cows each year. It can also allow

more efficient use of feed supplies and extend the marketing season. A controlled calving season is still possible in a split calving system, but additional labor and pasture facilities are required.

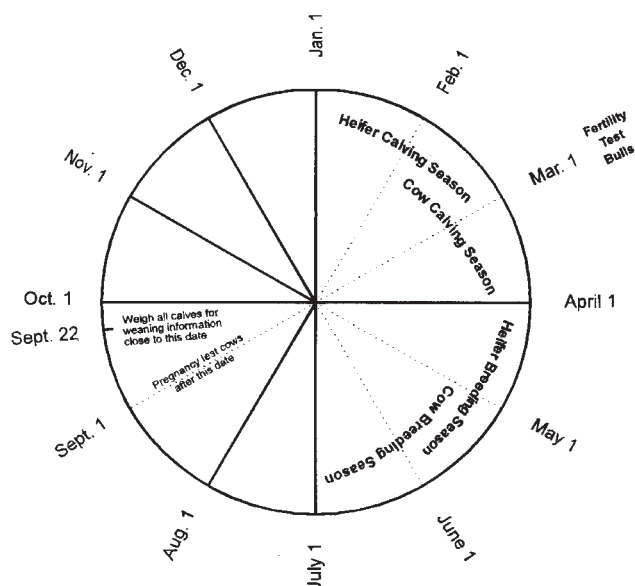

FIGURE 19. Calendar for 60-day calving-breeding season.

### Breeding Management

Good breeding management starts several months before the bulls are turned in with the cows. Proper development of young bulls and replacement heifers and proper nutrition of cows from six weeks prior to calving and continuing through the breeding season are necessary to ensure early estrus and high conception rate.

Other breeding management techniques during the season that will be advantageous are:

- Expose heifers approximately 30 days before the breeding season selected for the mature cow herd. This allows 30 extra days for young cows to recover from calving and be ready to breed within the calving season their second year of production.
- Breeding heifers to bulls known to produce calves with small birth weights or with calving ease EPDs can greatly reduce calving difficulties.
- Separate heifers with their first calf from the mature cow herd and feed separately. First-calf heifers need feed to continue growth and

development in addition to the feed required for milk production and regular reproduction.

- Provide adequate “bull power” during the breeding season. The number of bulls required depends on the age and condition of the bulls, general herd health and the system of matings. A bull can service more cows when hand mated than when pasture mated. More bull power is necessary for a confined calving season than if the calving season is split or the cows are calving year-round. The general recommendation is one mature bull to 25 cows.

## Fertility Testing Bulls

Checking the bulls for fertility and breeding ability is insurance. The test should include a thorough physical examination by a veterinarian to determine if the reproductive organs are normal and functional. A semen evaluation should be made to determine motility of sperm and sperm abnormalities. A test service on one or two cull cows or heifers that are “in heat” provides some assurance of the bull’s ability to mate. The bulls should be in good breeding condition, not too fat and sound in feet and legs. If bulls are to be worked hard, you may need to provide grain or other high-quality feed. Alternating use of bulls during the breeding season can extend their usefulness and help prevent calf crop losses due to reduced bull fertility from overwork or injuries.

Evaluation of a bull should include a measurement of scrotal circumference. This ranks as one of the most useful and valid measurements of a bull’s breeding ability. Scrotal circumference is highly correlated with semen production capacity in young bulls. Research also has shown that bulls with larger testicles tend to sire heifers that reach puberty at a younger age. The diagram in Figure 20 indicates how this measurement is taken.

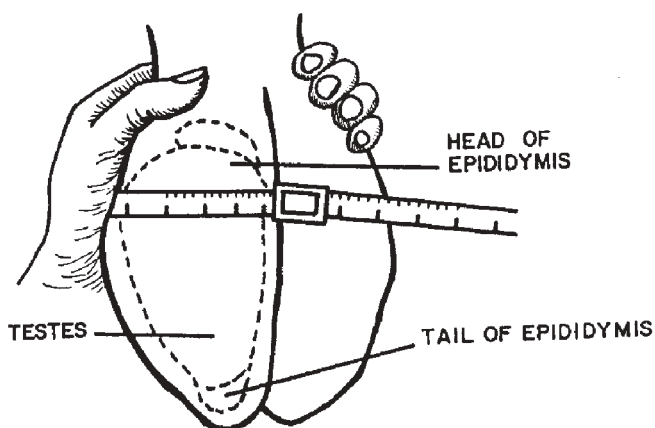

FIGURE 20. The proper way to measure scrotal circumference.

Semen quality should be determined by an experienced veterinarian. Semen is scored for **motility** and **morphology**. Bulls are said to have satisfactory semen if the sperm morphology is  $\geq 70$  percent normal sperm, sperm motility  $\geq 30$  percent individual motility and/or “fair” gross motility and a scrotal circumference that is equal to or larger than the preset standard for bulls of their age. Table 15 gives the scoring system recommended by the Society of Theriogenology.

Category	Threshold
Scrotal Circumference (cm)	30 cm at $\leq 15$ mo. 31 cm at $> 15$ mo. $\geq 18$ mo. 32 cm at $> 18$ mo. $\geq 21$ mo. 33 cm at $> 21$ mo. $\geq 24$ mo. 34 cm at $> 24$ mo.
Sperm Morphology	$\geq 70\%$ normal sperm
Sperm Motility	$\geq 30\%$ individual motility and/or “fair” gross motility

## Artificial Insemination of Beef Cows

The use of artificial insemination for beef cattle has increased tremendously in recent years, especially in purebred and large commercial herds. A major problem in artificially inseminating beef cows is heat detection under range conditions. Development of fairly successful heat detecting devices has lessened the problem. Still, much of the success or failure in artificially inseminating beef cows depends on the training, skill, carefulness and thoroughness of the ranch manager and the inseminator.

## Estrous Synchronization in Cattle

Estrous synchronization is the manipulation of the reproductive processes so that all females can be bred during a short, predefined interval with normal fertility. This control facilitates breeding in two important ways: it reduces, and in some cases eliminates, the labor of estrous detection, and it allows the producer to schedule the breeding. For example, if a herd can be induced to exhibit estrus at about the same time, the producer can arrange for a few days of intensive artificial or natural insemination. Estrous synchronization early in the breeding season should result in a large percentage of a herd calving earlier in the prescribed calving season, thereby producing heavier weaning weights.

It enables the producer to breed more cows to a selected bull, and it concentrates labor into shorter periods of time for breeding, calving and calf management procedures.

Advanced procedures related to estrous synchronization, superovulation, embryo transfer and artificial insemination continue to be researched and developed. Reproductive efficiency is one of the important economic considerations in beef cattle production.

## Embryo Transplantation

Embryo transplantation in beef cattle production has gained popularity in the last decade and will likely increase. Embryo transplantation involves the removal of an embryo, either surgically or nonsurgically, from a donor cow and implanting the embryo, either surgically or nonsurgically, into a recipient cow. The donor cow usually is super-ovulated in order to increase the number of viable embryos. Embryo transplantation likely will have greatest impact on the purebred cattle industry by increasing the number of progeny from an individual female. Only cows with proven production records should be used as embryo donors. Heifers and young cows should not be chosen as donors. Embryo transplantation is an expensive procedure. The expected value of a calf from embryo transplantation must be sufficiently great to offset the cost associated with the transfer. Calves produced by embryo transplantation pose special problems when their records are considered in selection programs, because their records contain variation associated with differences in maternal environment. Records of calves produced by surrogate mothers should not be compared to records of calves from natural mothers. Embryo transplantation has no practical application in the commercial cattle industry.

## Pregnancy Testing

Pregnancy testing by palpation is done by inserting the arm into the rectum and feeling the reproductive tract for pregnancy status. Short-term pregnancies are difficult to detect, so it is best to wait at least 45 days after bulls are removed to pregnancy test. Palpation is an art and skill. Most veterinarians, artificial insemination technicians and experienced cattle producers can make accurate pregnancy determinations. The cost for pregnancy checking is minimal when the expense of carrying an open cow for a year is considered. Pregnancy testing can aid in obtaining an acceptable percentage calf crop if low calving rate is a herd problem.

## Body Condition Scoring

Proper body condition of cows prior to calving plays an important role in continued successful reproduction in a herd. Scoring cows for body condition, at time calves are weighed for weaning, provides a basis of determining nutritional needs prior to the upcoming calving.

The plane of nutrition provided during lactation is the most important of several factors affecting the condition of brood cows. Differences observed in body condition within the herd may be due to age, soundness of teeth, milk production, general health or genetic variability. Extremely thin or fat cows may need to be fed separately or culled from the herd. The following score cards (Tables 16 and 17) will provide some guidelines for cow management:

Too Thin	1 — <b>Emaciated</b> — cow extremely emaciated, no detectable fat, prominent tailhead and bare ribs.
	2 — <b>Poor</b> — cow somewhat emaciated, little fat, spine, ribs, and tailhead somewhat prominent.
	3 — <b>Thin</b> — back and tailhead lightly covered, ribs individually identifiable, somewhat bare.
Borderline	4 — <b>Borderline</b> — ribs not visually obvious, some fat cover over ribs and pins.
Optimum	5 — <b>Moderate</b> — generally good overall condition, spongy fat cover over ribs and pins.
	6 — <b>High Moderate</b> — firm pressure required to feel spine, considerable fat cover over ribs.
	7 — <b>Fleshy</b> — cow appears fleshy, considerable fat cover, pones somewhat obvious.
Too Fat	8 — <b>Fat</b> — cow very fat, overconditioned, large fat deposits over ribs, around tailhead.
	9 — <b>Extremely Fat</b> — extremely wasty and patchy, extreme “pones,” impaired mobility.

TABLE 17. Weight Changes Needed by Calving Time and General Feed Recommendations for Beef Cows	
Too Thin	1 — Needs to gain 350 lbs (cull)
	2 — Needs to gain 300-350 lbs (cull)
	3 — Needs to gain 200-300 lbs, improved ration, grain needed
Borderline	4 — Needs to gain 150-200 lbs, improved ration, excellent forage
Optimum	5 — Needs to gain weight of fetus (100 lbs), good forage
	6 — Needs to gain weight of fetus (100 lbs), good forage
	7 — No weight gain needed, fair forage
Too Fat	8 — Needs to lose 50-100 lbs, limit ration, too fat to calve
	9 — Needs to lose 100-200 lbs, may need to be culled, usually low in fertility



FIGURE 21. BCS 3.



FIGURE 22. BCS 5.



FIGURE 23. BCS 7.

## Management at Calving

Most calf losses at birth are due to abnormal or difficult deliveries. At least half of the losses at calving time can be prevented by proper observation and assistance when needed. First- and second-calf heifers should be given special attention because most calving losses occur with this age group.

Location of a calving site is important for ease of observation. Observation of cows every 4-6 hours is generally adequate to detect difficulties. As the cow approaches parturition she becomes nervous and restless. Labor pains begin a few hours before birth and increase in both frequency and intensity until delivery. Most cows will attempt to calve in seclusion away from both man and other animals if given a choice.

The cow will normally calve within a 1- to 3-hour period from the first signs of attempted delivery. She should be left alone if calving proceeds normally. If the calf has not been delivered within three hours, examination and assistance are in order. A normal presentation is both front feet first with the head on the knees. An inexperienced producer should obtain the prompt services of a veterinarian when difficulties in delivery are encountered.

A strong, healthy cow will usually care for her newborn calf, especially if delivery has been normal. Determine if the calf is breathing when born. If the nostrils are covered with fetal membranes or filled with mucous fluid, they should be cleared.

A normal calf should stand and nurse within 30-45 minutes after birth. Weak or chilled calves may require assistance to obtain a first feeding of

colostrum (first milk). This milk provides highly concentrated food nutrients and antibodies helpful in preventing calf diseases and digestive disorders. It is essential.

The cow should expel the placenta, or afterbirth, from her reproductive tract. If the cow does not clean out normally within 24 hours, contact your veterinarian. A retained placenta putrefies rapidly and may cause toxemia (blood poisoning).

For the first few days after birth, watch for scouring in the calf and see that the calf is nursing all quarters of the cow's udder. Sometimes heavy milkers or cows with large teats need to be "milked out" a few times to prevent the udder from spoiling.

## Managing the Calf Crop

A calf management program should begin with individual animal identification. Calves are identified to (1) provide positive identity for recording performance and family relationships and (2) serve as a means to establishing legal title. A number of methods provide good permanent identification for a record program. These methods include (1) ear tattoo, (2) hot iron brand, (3) freeze brands, (4) chemical brands and (5) ear notching. Temporary identification, such as chains, nylon cords or eartags, may also be used for easy identification. Some horned cattle breeders use horn brands. Paint brands and stick-on tags are often used for very temporary identification, usually associated with marketing.

The ear tattoo is widely used by breed registry associations and cowherd performance testing programs as a method of permanent identification.

A number brand is second in use to the ear tattoo as a permanent means of individual animal identification. Number brands are usually applied with a hot iron. The hot iron brand has been an integral part of the heritage of the beef cattle industry in the western range states. Originally brands were used only as a means of ownership identification, and ownership brands are still important in many areas of the country. There are rigid brand registration laws in many states. In Arkansas, state registration of your brand is not required by law, but brands of record take precedence over

unrecorded brands of like and kind when there is question of ownership. Brands should be registered with the Division of Brand Registry, Livestock and Poultry Commission, Little Rock, Arkansas.

Permanent number brands may also be applied by freeze branding. This method is popular with some producers. Branding technique determines the success or failure of freeze branding.

Soft-type plastic ear tags are probably the most widely used method of temporary identification. Often the ear tattoo and ear tags are both used simultaneously on an animal. Tags are easy to read, and the ear tattoo provides identification should a tag be lost.

## Castration

Steer calves are preferred over bull calves in the feeder market. Bull calves should be castrated if not intended to be retained for breeding purposes. Castration can best be done when the calf is quite young. Older calves are more difficult to restrain and suffer a greater set back. Many cattlemen castrate newborn calves at the same time they tattoo them for permanent identification.

Surgical castration is the most positive method of castration and is preferred by many stockmen. The young calf is restrained, the lower third of the scrotum is opened with a scalpel or Newberry knife, the testicles are then pushed one-at-a-time through the incision where it is separated from the membranes. The spermatic cord is severed usually by scraping with a knife blade. An antiseptic should be applied to the wound, and if castration is performed during fly season, an insect repellent should be applied.

Emasculating, or clamping, is a bloodless method of castration. Each cord should be carefully crushed separately. Make certain to leave the median unclamped for free circulation of blood to the scrotum. Improper clamping will result in a large number of stags.

Elastration is another bloodless method of castration. This method runs a rather high risk of tetanus or other clostridial infections. Also, the rubber rings sometimes fail to hold until the operation is complete.

## Dehorning

Cattle without horns attract some preference over horned cattle in the market. Hornless cattle require less space in transit, in the feedlot and at the feed bunk. They fight less and inflict fewer injuries to each other. There are several effective methods of dehorning, depending on operator preference and age of the animals.

**Genetic** – Crossing cows with a bull that is homozygous for the polled trait is an often overlooked solution to dehorning. All calves from such a mating will have no horns. Likewise, if your cowherd is comprised of a polled breed, you can breed to a horned bull and all calves will be polled without the expense incurred with other dehorning procedures.

**Chemical Dehorning** – A caustic paste or stick can be used on very young calves (up to two or three weeks of age) where only a button can be felt. Clip the hair from over the horn button and apply petroleum jelly below the area to protect the calf's eyes. After applying caustic, keep the calf in the dry and away from its dam until the treated area is hardened or dried. Be careful to avoid contact of the chemical with your skin or eyes.

**Spoon or Tube Dehorners** – Horn buttons or small horns just emerging can be readily removed with spoon or tube dehorners. The tube must be large enough to fit over the base of the horn and include about one-eighth of an inch of hair around the horn. Push and twist until the skin has been "cut through" and then, using the cutting edge of the tube, cut or scoop under the horn and remove it. Apply an antiseptic and an insect repellent if needed.

**Hot Irons** – A hot iron may be used to dehorn calves with buttons or small horns. Fire-heated irons usually come in sets so the proper size can be selected to fit over the base of the horn. Heat the iron to a dull red. Electrically heated irons are designed to maintain the proper temperature. Success depends on holding the hot iron in place long enough to destroy the ring of growth cells around the base of the horn. This method of dehorning is practically bloodless and one of the most satisfactory methods available when properly used on the right age calf.



– Tube dehorner



– Hot iron dehorner



– Electric dehorner

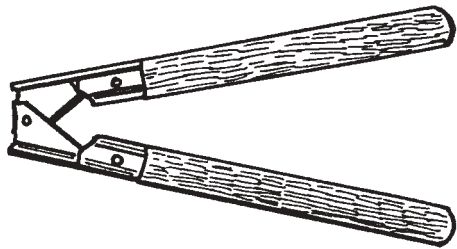

– Mechanical dehorner (Barnes type) especially adapted to dehorning calves. This type is available in two sizes, the larger of which can be used in dehorning animals that are up to about a year old.

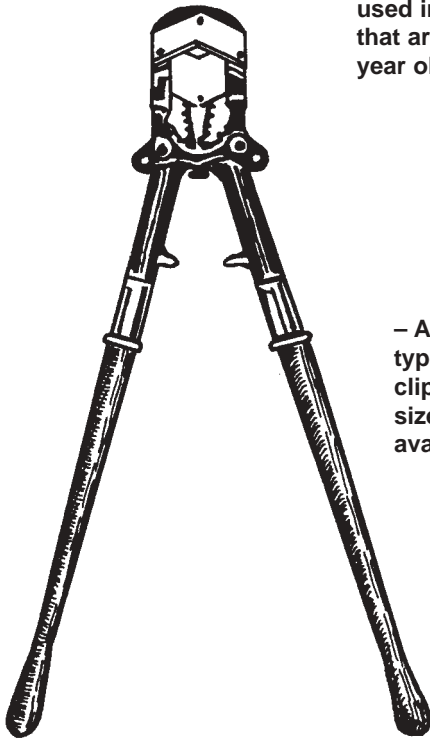

– A commonly used type of dehorning clipper. At least two sizes usually are available.

FIGURE 24. Types of dehorners.

**Barnes Type Dehorners** – Barnes type dehorners can be used on horns too large for tube or hot irons but small enough for the instrument to fit properly and permit cutting a ring of skin and hair. Barnes type dehorners are available in calf and yearling sizes. Close the handles to fit the blades around the base of the horn. Spread the handles and twist while applying considerable pressure against the skull to remove the horn. Hemorrhage may need to be controlled by pulling major exposed arteries with forceps. Apply a non-irritating antiseptic and fly repellent if needed.

**Removing Large Horns** – Cattle with horns too large to remove with the above methods can be dehorned with a saw, clippers or obstetrical wire. Removal of a ring of skin and hair around the horn is essential in all cutting methods of dehorning, not only to prevent regrowth but also to expose the arteries so hemorrhage can be controlled. Dehorning wounds in large cattle heal slowly and care must be taken to prevent sinus infection and fly-blow. Cost and risk should be carefully weighed against expected benefits.

## Creep Feeding Nursing Beef Calves

Creep feeding is the practice of providing supplemental feed, usually grain, to nursing calves in a facility that prohibits the brood cow from having access to the feed. Even though creep feeding will almost always yield a response of increased growth rate in calves, it is not always economically profitable.

Creep feeding of beef calves is certainly not a practice that is routinely recommended in commercial beef herds. Creep feeding may be worthwhile in the following situations:

- periods of drought
- poor milking cows
- calves from first-calf heifers and old cows
- cows on poor pasture
- just before weaning to teach calves to eat
- calves being fed for slaughter at weaning

Situations under which creep feeding is probably not profitable are:

- cows with good milking ability
- pastures high in quality and abundant, such as clover-grasses
- calves to be grazed or backgrounded at relatively low rates of gain after weaning
- heifer calves being raised for replacements

Generally, creep feeding is not profitable when calves are receiving sufficient feed from other sources to grow at their genetic potential, although sometimes purebred beef cattle producers find it advantageous to creep-feed calves to be sold for breeding stock. The better conditioning and bloom of hair coat is attractive to buyers.

## Weaning

Weaning is a distress period for both calf and cow. Calves are made to break the nursing habit and rely on feedstuffs other than milk for their growth and subsistence by separation from their mothers. Both cow and calf bawl and go off-feed for two or three days. The calf is particularly susceptible to various disease organisms at this time.

Weaning should be done early enough to allow cows sufficient rest prior to their next calf. A two- to four-months' rest between calves will allow the cow to regain condition lost during lactation and improve her mothering ability with the next calf.

## Growth-Stimulating Implants

A growth implant is a substance implanted into the body (usually ear) for growth promotion. Research data strongly indicate a positive and economical response to implants. Extensive use of these materials is being made by feedlot operators and stocker growers. Increased use of implants by calf producers has occurred in recent years.

Livestock producers should be aware of current restrictions on the use of these materials. FDA constantly monitors their use, and regulations are issued periodically which must be adhered to.



FIGURE 25. Implanting for increased weight and profit.

## Feed Additives

Various additives have been tested in recent years to determine their value in beef cattle feeding. These materials are most frequently used in feedlots but may sometimes be fed to other classes of cattle in specific situations.

Antibiotics have been used to increase feedlot gain and reduce the incidence of liver abscesses. Those most frequently used have been medicated minerals containing chlortetracycline (Aureomycin®), oxytetracycline (Terramycin®) or tylosin (Tylan®). Bacitracin (Baciferm®) and Neomycin® have also been approved by FDA as feed additives. Other additives have included coccidiostats and anthelmintics.

Rumensin® (monensin sodium) and Bovatec® (lasalocid sodium) are two examples of feed additives that can promote improvement in feed efficiency and rate of gain in beef cattle. These substances alter the metabolic pathways of the fatty acids formed from cellulose (associated with forage) and starch (associated with grain). Propionic acid is produced more efficiently than either acetic or butyric acid, the other commonly produced fatty acids. Rumensin and Bovatec alter rumen bacteria to favor propionic acid production; hence, more efficient use of energy by cattle. Cattlemen should

follow current FDA-approved uses for these feed additives. Rumensin is toxic to horses and may be fatal.

Sodium bicarbonate has been around for many years and has been used in treating digestive disturbances. Its buffering action, when included in feedlot rations containing high levels of grain, has shown to improve both rate of gain and feed efficiency. It reduces stress on cattle, especially at the beginning of the feeding period (about 50 days) by lowering the risk of rumen acidosis.

MGA® (melengestrol acetate) when added to feedlot heifer rations stops the normal hormone production sequence that produces estrus. Because feeding the exact recommended level of MGA prevents estrus but allows the optimum level of estrogen production, feedlot heifers gain at an increased rate. FDA gave clearance for combined feeding of MGA and Rumensin to feedlot heifers, combining their benefits.

Feed additives are continually being researched and offered to the beef cattle producer. Each producer should determine if the material in question offers an economic advantage in his production situation. Strict adherence to FDA regulations, including preslaughter withdrawal, is best accomplished by reading and following label directions.